

The Use of Building Simulation within an Architectural Practice

Dan Hobbs¹, Christoph Morbitzer¹, Brian Spires¹, Paul Strachan[#], and Jim Webster¹

¹HLM Design, [#]ESRU, University of Strathclyde

Summary

This paper documents the development and implementation and use of simulation within an architectural practice and reports how its use facilitates the practice's commitment to Sustainable Design.

The company perceives that quantification of energy, environmental performance and life-cycle design parameters are now key elements of the design decision-making process, which should be judged in a holistic framework and at the very earliest stages of the design process where they can have their greatest impact.

The paper presents the company's objectives with regard to achieving sustainability through the adoption of new tools and strategies and outlines how these ideas have impacted on both the design process and its outcome. The benefits are illustrated through a case study of a recent project. Finally, the paper concludes with a report on the impact upon the company's business overall and a discussion on the lessons learned during the experience of integrating simulation into the design process.

Introduction

The UK Construction Industry has undergone what many see as a minor revolution, with the creation of new models of procurement and changes in the way we design, construct and value buildings. Changing Government policy, legislation, procurement routes and customer demand in particular has led to a move towards a new environment of sustainable development, which has impacted significantly on the design process within an architectural practice.

This paper outlines the impact these changes have had on the design and procurement of built facilities and how one particular architectural practice has responded to such changes.

This paper focuses on the key changes made by the practice to the architectural design process in order to satisfy its sustainability agenda.

The practice perceives that simulation can provide unique benefits to a sustainable design approach, whereby it becomes fully integrated into the new process, and in such a way that Architects can fully engage in its use and at a time when it had greatest impact on the outcome.

The Sustainable Design Approach

The need for a Sustainable Design Approach within the architectural practice was highlighted as early as 1998, through a future-focused management team that realized (initially within the PFI context), that this changing environment would need to be addressed if new benchmarks were to be met, and the practice was to retain its competitive edge. Through UK Government's Teaching Company Scheme (TCS) initiative [2001], funds were made available to facilitate this change. The first phase of this technology and knowledge transfer was in the development of a simulation tool for use by architects at the earliest stages of the design process [Morbiter et al 2001].

The embodiment of modelling as a standard component of design practice procedures within an architectural practice presents a number of barriers, not least of which is that dynamic building simulation programmes are highly complex and require a level of expertise that does not normally reside with architects.

Historically, building simulation is undertaken, in the main, by specialised environmental systems engineers or research groups (commercial, government funded or academic), usually focused on specific problems [McElroy et al 1999]. This situation gives rise to simulation exercises being undertaken, generally, at a later stage in the design process (scheme or detail design stages [RIBA 1995]) with the purpose of validating design decisions. The reasons for this situation is predominantly due to the limited availability of resources for simulation work at early design stages and limited understanding of the benefits of using simulation by design team members. The architectural practice realised that the main benefits to the use of simulation are to be gained from its early use within design process when rapid feedback is a big priority in the decision making process. The practice believed that the improved understanding which results from this process, leads to improved design solutions.

An Outline Design Stage (ODS) interface [Morbitzer et al 2001] was developed to facilitate straightforward data input by non-specialists. The ODS Interface is based on an existing and advanced simulation tool esp-r [ESRU2003]. The interface is now used routinely on all projects at concept design stage [RIBA1995], by architects. The inputs, facilitated through extensive databases, are a representative geometric model, built using the practice's existing CAD software, various climatic, constructional, operational, and control data. The dynamic simulation is run and the output of the simulation is a figure for 'intrinsic' annual energy consumption and an assessment of thermal comfort.

The simulation tool enables quantification of specific design parameters that are of importance in the production of sustainable design. However, sustainability is a complex recursive process and although the outputs from the tool are important, other parameters still remain poorly understood and quantified.

Adoption of new tools and strategies

There now exists a need to demonstrate design concept performance against key design parameters such as energy consumption and environmental impact along side, floor plate efficiency, flexibility, etc. Simulation offers a means of quantification of some of these parameters. Figure 1 outlines the current framework for the use of simulation within the architectural practice, and how the outputs from the simulation are used and the quality of results assured. The framework is based around Clarke's definition of the Computer Supported Design Environment (CSDE) [Clarke 2001] to provide *feedback on all aspects of performance and cost in terms meaningful to the designer*.

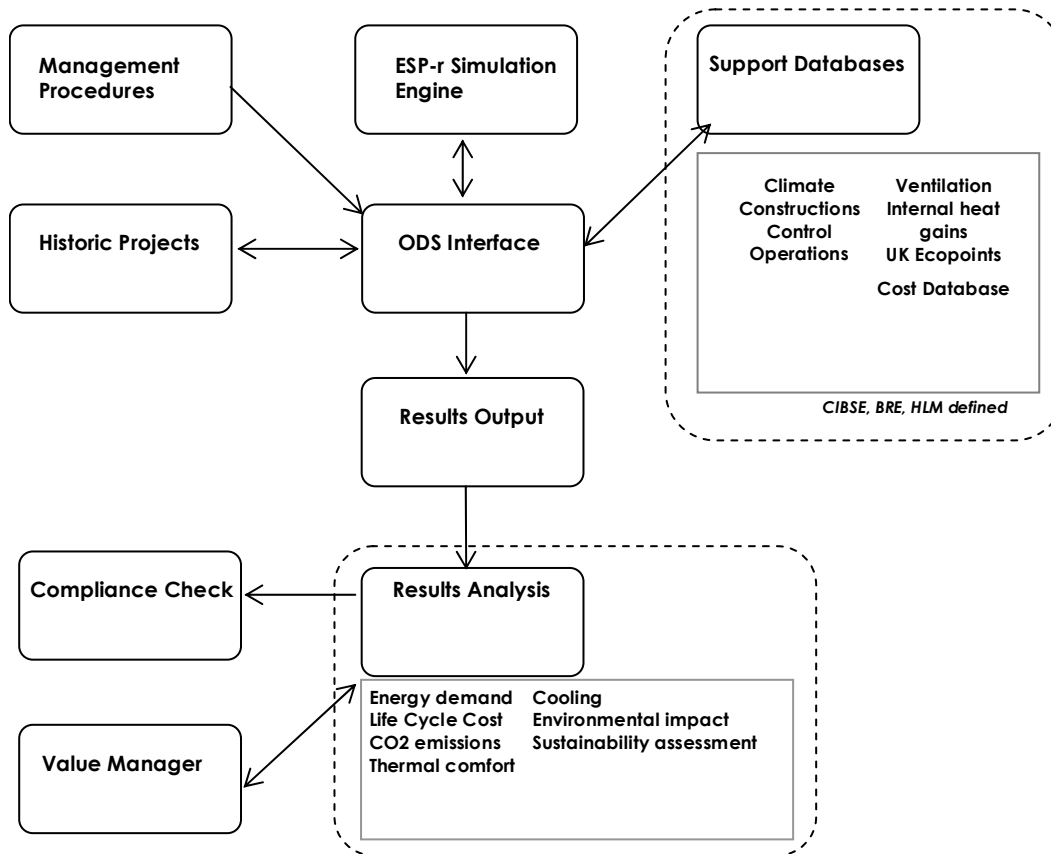

Figure 1 – Sustainable Design Framework

Impact of framework on design process/outcomes

The case study that is documented here outlines some of the key issues with regard to adopting new processes and tools within the design process.

The case study discusses a situation where a developer has approached the architectural practice to assess the feasibility of a sustainable speculative office development. The methodology for this study is highlighted below and is based on [Blyth & Worthington 2001].

The first phase of the process involved interrogating the statement of need from the client, followed by an assessment of the client and user needs, an assessment of options available and the development of the strategic brief that included the setting of performance targets to enable a holistic design concept appraisal.

During this process a ‘stakeholder workshop’ was undertaken which facilitated understanding of the issues of sustainability from various perspectives within the construction industry and brought together various senior managers to discuss sustainability at a strategic level. The

workshop was particularly useful in identifying key issues that will need to be addressed for a more pervasive take-up of the sustainable development tenets.

Some of the key issues that were highlighted are outlined below:

- Further to disseminate of the issues of sustainability at the various scales.
- Further to greater collaboration between design team members, clients and users..
- Government to lead in developing a framework for sustainability using legislative measures.
- The use of new technologies, tools, strategies and processes.
- Develop markets through quantification of the degree-of-sustainability of built facilities.

With the development of a strategic brief and agreement to the level of performance the team carries out a feasibility study which incorporated explicit design concept evaluation against benchmarks, best practice and simulated performance. A typical example (Class 4 specification [ECON 2000]) was chosen from the Clients previous office developments for simulation by the team, using the ODS Interface, to assess the current levels of performance and set a base case for design concept appraisal.

The use of simulation in this part of the project was crucial in understanding what levels of performance could be expected. Many of the benchmarks that currently exist contain a high level of uncertainty. This is due to various factors such as the currency of the data, source of data, and the specification of the building being considered.

The precedent was chosen by the client and design team and was used to assess the level of performance that should be aimed for, with the design options for a sustainable office.

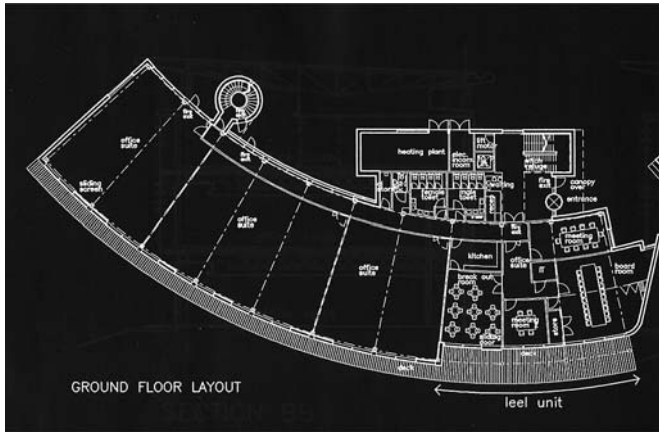

Figure 2 - shows the ground floor plan arrangement

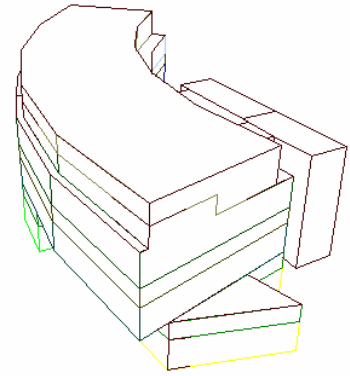

Figure 3 - shows the geometry model used in the simulation

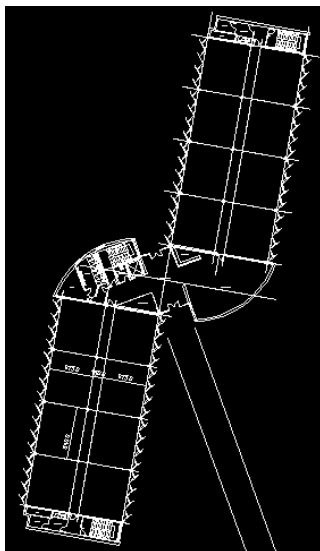

Figure 4 – The Ground Floor Plan arrangement of preferred option

Figure 2 shows the floor plate arrangement for the typical precedent forwarded for simulation by the client; Figure 3 shows the 3D model used in the simulation by the design team; Figure 4 shows the ground floor arrangement for the chosen design option.

From this typical precedent a comparative analysis table was set up to interrogate performance of the preferred design option against best practice benchmarks and simulated precedent.

The case study focused on a specific application of simulation within the sustainability context on a specific project to set and interrogate the applicability of existing benchmarks.

The case study identified a number of benefits to the use of an explicit design decision making methodology which include:

- A greater understanding, by all parties, of the design outcomes which leads to improved decision making.
- The process encouraged a greater level of ownership and collaboration amongst the team (including the Client).
- Improved Client satisfaction.

Impact of 'sustainability' in practice

The adoption of a Sustainable Design Approach in which its designers have gained first hand experience of simulation, has broadened its architects knowledge and appreciation of its underlying behaviour of a building and its systems and enabled the architectural practice to demonstrate a more holistic approach to the design. This in turn attracted new job opportunities that would have not been available previously.

The adoption of an explicit design-decision making process has improved project control and design-decision making leading to improved client satisfaction and improved value to client.

The sustainable design approach developed within the architectural practice has improved understanding within the practice on the key issues of sustainability.

Lessons learnt through integration of simulation

The use of simulation by non-experts i.e. architects is an activity that is not without risks.

Two key areas of risk could be considered to be increased liability of the architectural practice through the prediction of building performance and the risk of error in model creation that is a

factor of poor input or is attributable to a lack of knowledge of energy simulation by architects or both!

The issue of liability is overcome, by making it clear to the Client and the other design team members that the results from the simulations are for comparative analysis only, to aid in design-decision making and not a guaranteed prediction of how the building may perform in its final form.

The mitigation of risks associated with poor input or lack of knowledge of energy modelling has been overcome within the practice in two principle ways:

Development of specific quality assurance procedures

- Development of training/education in building simulation (training within the practice is undertaken in a seminar type fashion usually attended by 7-10 individuals, that typically lasts 2-3 days) The training starts with background information to the benefits to simulation, then an introduction to the interface, followed by 'hands-on' experience of using the software on an example project.

Quality Assurance procedures have been developed and integrated into the ODS interface [Morbiter 2003] to:

- Provide a checking mechanism as to whether or not a simulation exercise is necessary
- Ensure that financial and human resources required for the exercise are available.
- Agree deadlines that can be met by all parties and provide performance predictions in the time frame required by the design team.
- Ensure that either an external or internal practitioner approves data used for the model creation and that data sources (as well as the person(s) who approved the data) are documented.

- Ensure that verification and validation of the simulation model are applied (both the verification and validation of the model and simulation results are undertaken by a third party, either an in-house expert or an external consultant, depending on the complexity of the exercise).
- Ensure that performance predictions are reported in an understandable way and that the report with the performance predictions explains the basis on which they were produced (e.g. input data used, model accuracy applied).

Conclusions

Changing procurement methods, policy, legislation and customer/client demand is driving a change within the construction industry towards sustainability.

Architectural practices may need to change their working processes to mitigate the risks of these changes

The use of an explicit design decision making methodology aids in understanding design outcomes and facilitates improved design decision making

The use of simulation for quantification of design performance criteria such as, annual energy consumption and comfort conditions supports the explicit design decision making process.

Through better understanding of the design problem through the appraisal methodology and use of simulation better design outcomes can be expected, which leads to improved client satisfaction.

Collaboration amongst design team members is crucial in assessing which of the design performance criteria are of relevance and for effective interrogation of the performance of any design outcome.

Appropriate benchmarks need to be developed and research undertaken to assess and validate these benchmarks against actual performance; Post Occupancy Evaluation (POE) is likely to play an important role in this area.

Explicit management procedures facilitate the use of simulation by non experts and control the risks associated with the use of simulation in that situation.

References

BCO (British Council for Offices) “BCO Guide 2000 Best Practice in the specification for offices” BCO Publication 2000.

Blyth A., and Worthington J., “Managing the Brief for better design” Spon Press, 2001

BREEAM (Building Research Establishment’s Environmental Assessment Method):

<http://www.bre.co.uk/service.jsp?id=51>

CIBSE (Chartered Institute of Building Services Engineering), “Energy Efficiency in Buildings”, CIBSE Publication, p 2-5, 1998.

CIRIA (Construction Industry Research and Information Association), “Sustainable Construction Procurement: A Guide to Delivering Environmentally Responsible Projects”, 2001.

Clarke J A, "Energy Simulation in Building Design", 2nd Edition, Butterworth Heinemann, 2001.

DETR (Department of the Environment, Transport, and the Regions), "Building a Better Quality of Life" 2000.

DTLR (Department of Transport, Local Government and the Regions), "The Building Regulations 2000, Part L2", 2002.

ECON (Energy Consumption Guide 19) "Energy Use in Offices" DETR 2000.

EEA (European Environment Agency) "Life Cycle Assessment (LCA): A Guide to Approaches, Experiences and Information Sources" Environmental Issues Series No.6, 1997.

ESRU: <http://www.esru.strath.ac.uk>, 2003.

GAIA "Sustainable Construction Drivers" Gaia Research CPD Module 2002.

Hart S., In Starkey R., Welford R., (Eds). "The Earthscan Reader in Business and Sustainable Development" Earthscan Publications 2001. *pp12-13*.

Hobbs D, "Report on Stakeholder Workshop: Speculative Sustainable Office Development", HLM Design Company Report 2003.

Hobbs D., Morbitzer C., Spires B., Strachan P., Webster J., "Experience of using Building Simulation within the Design Process of an Architectural Practice" Proceedings of the 8th IBPSA Conference (Building Simulation '03), Eindhoven, 2003.

ISE (Institute of Structural Engineers) “Building for a sustainable future: Construction without depletion” The Institute of Structural Engineers, November 1999.

LEED (Leadership in Energy and Environmental Design):

http://www.usgbc.org/LEED/LEED_main.asp

Morbitzer C, “Towards the Integration of Simulation into the Building Design Process”, PhD Thesis, University of Strathclyde, 2003.

Morbitzer C, Strachan P, Webster J, Spires B, Cafferty D, “Integration of Building Simulation into the Design Process of an Architecture Practice”, Proceedings of the 7th IBPSA Conference (Building Simulation ‘01), Rio de Janeiro, 2001.

NHS Estates “Sustainable Development in the NHS”, The Stationary Office, 2001.

RIBA (Royal Institute of British Architects), “Architect’s Job Book”, RIBA Publications, 1995.

TCS: <http://www.tconline.org.uk>

Acknowledgements

Scottish Enterprise Edinburgh and Lothian for their support and expertise during the case study.

SESG for the continued support and expertise with respect to the implementation of simulation into industry.

The University of Strathclyde for the involvement in the TCS as the Academic Partner